

Dispermill X-Proof HX220

 Pilot Dissolver

The Dispermill X-Proof HX220 is designed for the bigger laboratory research and development projects and pilot plants. The H-shaped floor stand ensures stability on the dissolver and the counterweight provides a balance that eases to move the machine up and down with the ergonomic lever. The powerful motor maintains its selected speed, independent of changes in viscosity. This guarantees optimum performance for your dissolving process. Besides, the stainless steel design is easy to maintain.

SAFETY FIRST

Your safety is very important to us. Safety interlocks for vessel detection and operation height are developed to ensure that no hazardous situations occur. This means that you can focus on your activities without being worried. The X-Proof HX220 is designed to operate in potentially explosive atmospheres.

APPLICATION

The Dispermill X-Proof HX220 fills the gap between the laboratory and the production dissolvers. Do you need a bigger testing sample or a smaller production batch and a machine that operates in potentially explosive atmospheres? That's where the Dispermill X-Proof HX220 comes in.

FEATURES

- ✓ Speed control by frequency inverter
- ✓ Digital speed readout
- ✓ Separate electronic cabinet
- ✓ Vessel clamping system
- ✓ 5 m cable between dissolver and electric cabinet included (other length on request)
- ✓ 125 mm dispersing disc included



Dispermill X-Proof HX220

2.2 kW, 0 - 4.000 RPM, 15 L - 150 L

Order code

10-1065

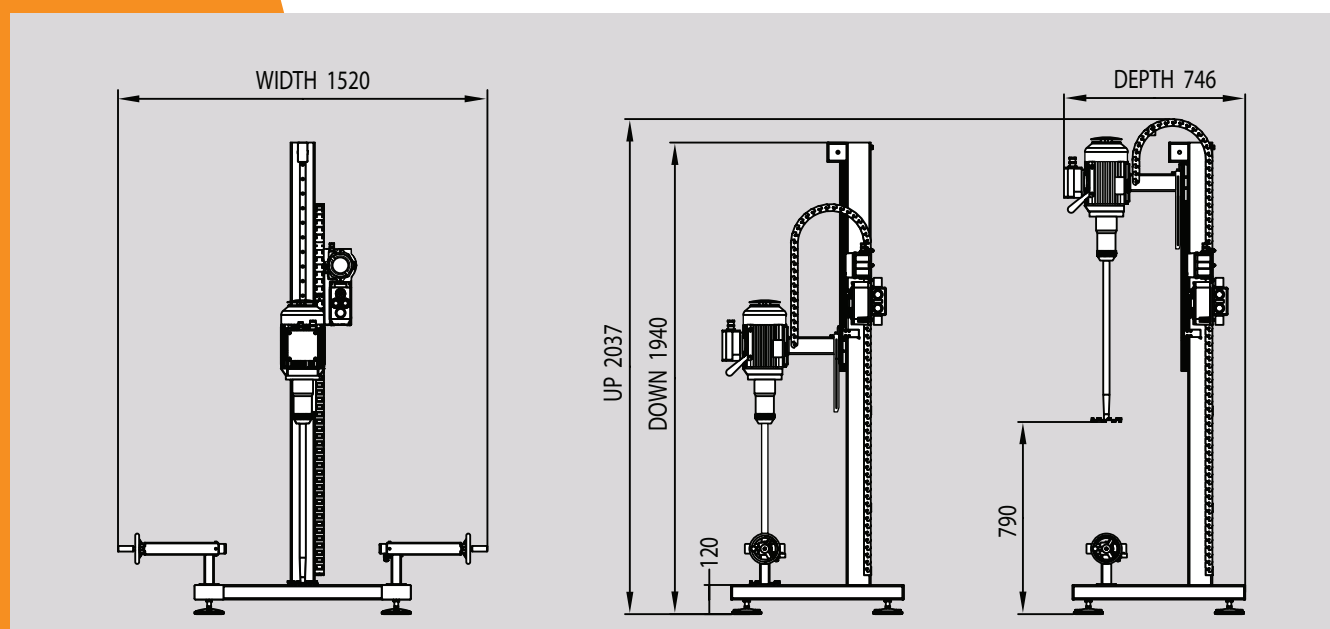

TECHNICAL SPECIFICATIONS

Power	2,2kW / 3 HP
Supply	400V +/- 10% 50/60 Hz, 16 Ampere
Protection class	 II 2G IIB T3
Speed	0 till 4.000 RPM
Thermal protection	PTC Temperature sensors
Volume range vessel	15 - 150 L
Diameter vessel	150 - 630 mm (min. - max.)
Height vessel	300 - 780 mm (min. - max.)
Dispersing disc	125 mm (interchangeable)
Dimensions (in mm)	746 x 1520 x 1940/2036 (D x W x H)
Weight	+/- 170 KG
Readout	True shaft speed on clear blue display
Safety CE	Conformity Directive 2006/42/EC

OPTIONS



Arms clamping system
(included)

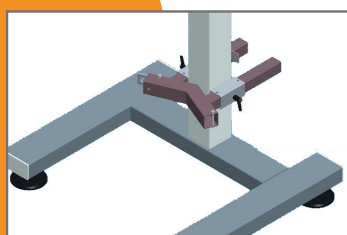

Belt clamping system
12-1038

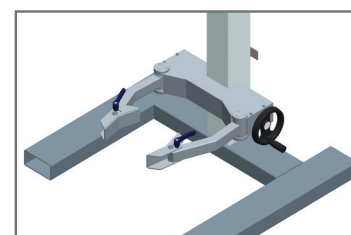

Central clamping system
24-1292

- 12-1036 Power readout in kW
- 12-1031 Mechanical timer with automatic stop 120 min
- Vessel cover systems on request